

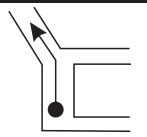
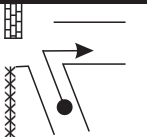
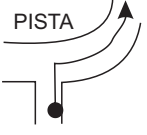
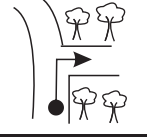
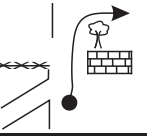
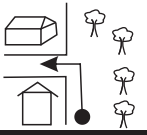
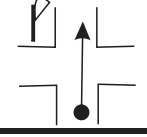
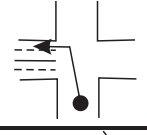
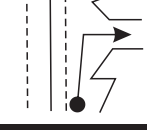
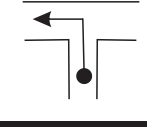
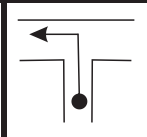
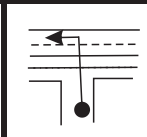
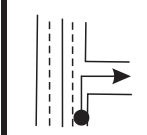
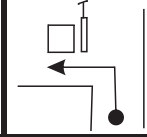
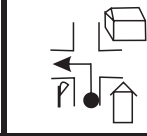
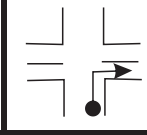
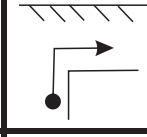
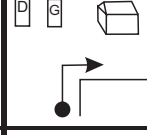
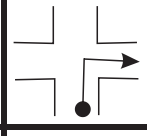
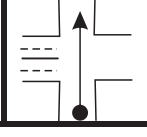
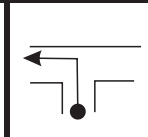
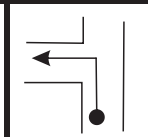
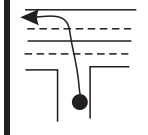
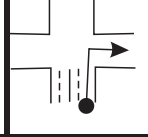
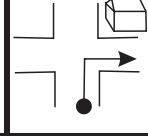
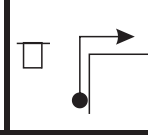
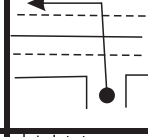
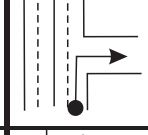
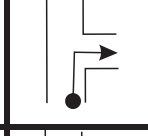
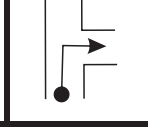
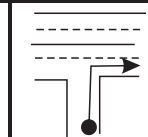
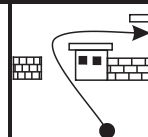
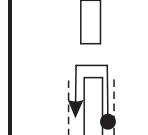
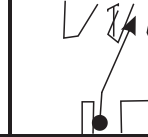

7 ENDURO 15° pbm		1
9 0,00		0:00:00
8 0,06		0:00:24
12 0,09		0:00:38
12 0,51		0:02:44
13 0,54		0:02:53
12 0,65		0:03:23
12 0,67		0:03:29
12 0,71		0:03:41
12 0,79		0:04:05
12 0,86		0:04:26
livre/ duplas pro		1

7 ENDURO 15° pbm		2
13 0,92		00:04:44
15 1,01		00:05:09
14 1,06		00:05:21
13 1,09		00:05:29
12 1,20		00:05:59
13 1,24		00:06:11
13 1,25		00:06:14
13 1,29		00:06:25
13 1,30		00:06:28
13 1,34		00:06:39
livre/ duplas pro		2

7 ENDURO 15° pbm		3
18 1,39		00:06:53
15 1,47		00:07:09
18 1,55		00:07:28
15 1,64		00:07:46
16 1,67		00:07:53
16 1,78		00:08:18
17 1,82		00:08:27
18 1,86		00:08:35
17 1,95		00:08:53
13 2,00		00:09:04
livre/ duplas pro		3

7 ENDURO 15° pbm		4
11 2,08		00:09:26
10 2,24 0,00		00:10:18
10 0,12		00:11:02
11 0,26		00:11:52
12 0,38		00:12:31
12 0,46		00:12:55
11 0,56		00:13:25
10 0,72		00:14:18
10 0,79		00:14:43
14 0,95		00:15:40
livre/ duplas pro		4

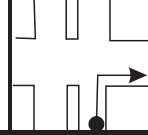
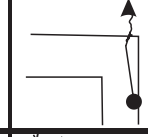
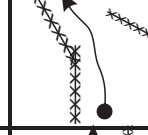
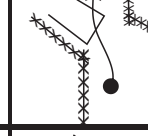
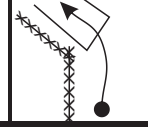
7º ENDURO 15º BPM		5
17 1,08		00:16:14
13 1,19		00:16:37
15 1,40		00:17:35
13 1,53		00:18:06
10 1,83		00:19:30
6 1,91 0,00		00:19:58
8 0,21		00:22:04
7 0,28		sempre feche 00:22:36
7 0,87		porteira fechada 00:27:39
10 0,90 0,04,00		NEUTRAL 00:27:55 00:31:55
livre/ duplas pro		5



7º ENDURO 15º BPM		6
9 0,99		00:32:27
12 1,07		00:32:59
12 1,14		00:33:20
12 1,21		00:33:41
9 1,35		pegue a trilha 00:34:23
9 1,38		00:34:35
12 1,43		00:34:55
12 1,62		00:35:52
12 1,68		00:36:10
13 1,75		00:36:31
livre/ duplas pro		6

7º ENDURO 15º BPM		7
13 1,81		00:36:48
13 1,88		00:37:07
15 2,15 0,00		00:38:22
15 0,06		00:38:36
15 0,12		00:38:51
15 0,39		00:39:55
15 0,45		00:40:10
15 0,72		00:41:15
18 0,79		00:41:31
18 1,06		00:42:25
livre/ duplas pro		7

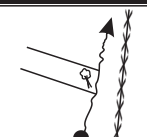
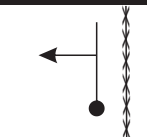
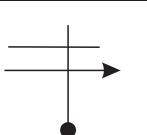
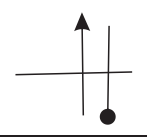
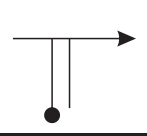
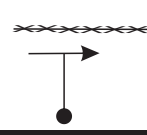
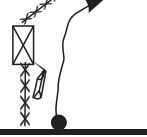
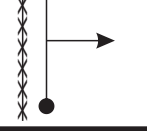
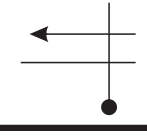
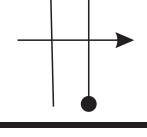

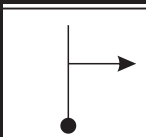
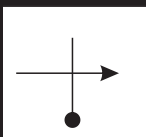
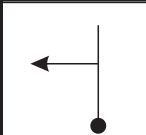
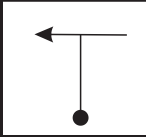
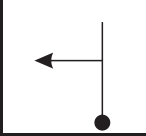
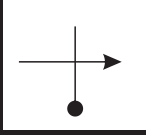
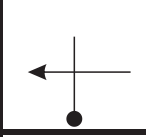
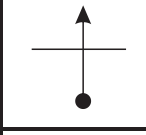
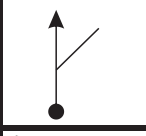
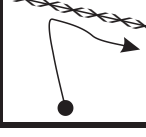
7º ENDURO 15º BPM		8
14 1,12		00:42:37
13 1,19		00:42:55
13 1,25		00:43:12
14 1,31		00:43:29
12 1,37		00:43:44
12 1,51		00:44:26
22 1,57		00:44:44
30 1,60		00:44:49
25 1,69		00:45:00
11 1,72		00:45:04
livre/ duplas pro		8

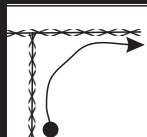
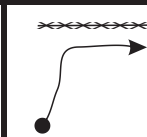
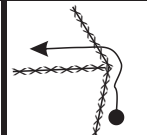
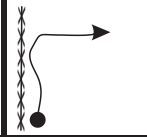

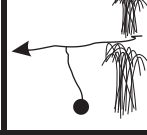
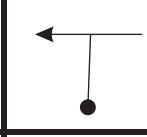
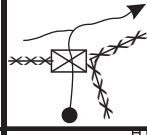
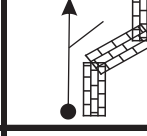
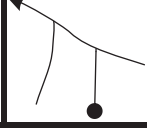

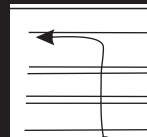
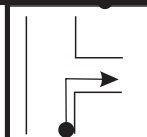
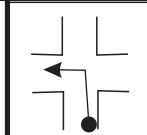
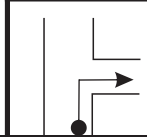
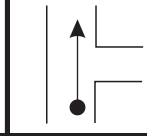
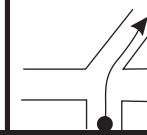
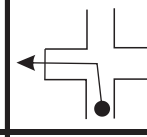
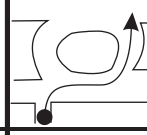
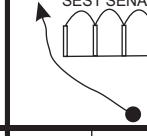
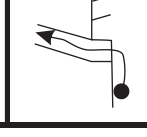
7° ENDURO 15° BPM		9
9	1,81	 00:45:34
9	1,97	 00:46:38
12 2,04	0,00	 00:47:06
15	0,06	 00:47:24
17	0,34	 00:48:31
18	0,46	 00:48:56
17	0,67	 00:49:38
15	0,76	 00:49:57
13	0,84	 00:50:16
13	0,92	 00:50:39
livre/ duplas pro		9

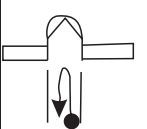
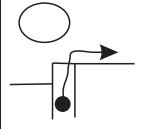
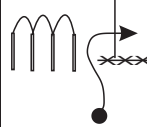
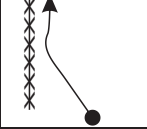
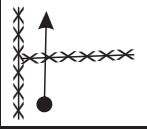
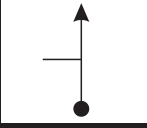
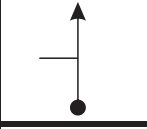
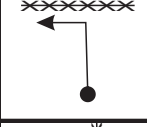
7° ENDURO 15° BPM		10
14	1,18	 00:51:51
15	1,24	 00:52:06
18	1,30	 00:52:20
12 1,57	0,00	 00:53:14
12	0,06	 00:53:32
13	0,33	 00:54:53
14	0,39	 00:55:10
15	0,45	 00:55:25
16	0,53	 00:55:45
7	0,68	 margeei cerca 00:56:18
livre/ duplas pro		10

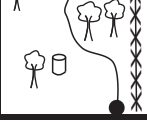

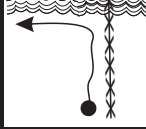
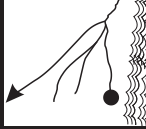

7° ENDURO 15° BPM		11
6	1,14	 NEUTRAL 01:00:15 01:04:15
18	1,50	 01:07:51
9 1,94	0,00	 01:09:19
11	0,06	 01:09:43
11	0,09	 bambu 01:09:53
14	0,12	 01:10:03
6	0,24	 01:10:33
10	0,53	 01:13:27
12	0,66	 patio veículos 01:14:14
10	1,06	 molas americanas 01:16:14
livre/ duplas pro		11

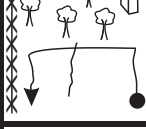
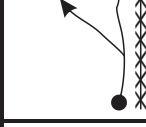
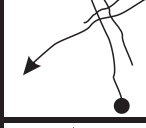
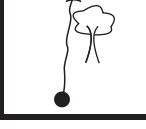
7° ENDURO 15° BPM		12
5	1,17	 empure bike 01:16:54 01:20:54
12	1,52	 01:25:06
12	1,68	 01:25:54
12	1,92	 01:27:06
12	2,01	 01:27:33
12	2,16	 01:28:18
12	2,23	 01:28:39
6	2,88	 01:31:54
6	2,98	 SEST SENAT direção ao sest 01:32:54
3	3,03	 01:33:24
livre/ duplas pro		12

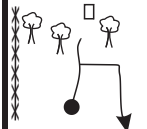
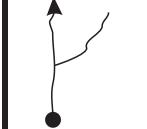
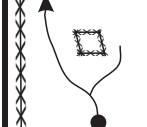
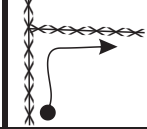
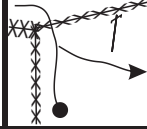
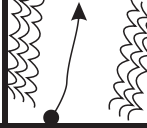
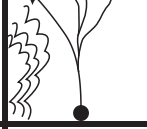
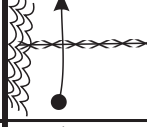
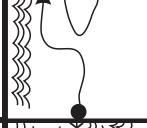
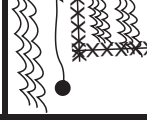
7° ENDURO 15° BPM		13
5 3,06 0,00 0,20,00		NEUTRAL 01:34:00 01:54:00
6 0,03		01:54:21
10 0,05		01:54:33
10 0,12		01:54:59
12 0,21		01:55:31
13 0,30		01:55:58
13 0,36		01:56:15
16 0,62		01:57:27
16 0,69		01:57:42
15 0,78		01:58:03
livre/ duplas pro		13

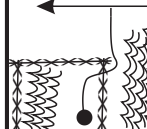
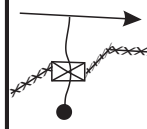
7° ENDURO 15° BPM		14
13 0,83		01:58:15
13 0,89		01:58:31
12 0,94		01:58:45
12 1,03 0,00		margeei lago 01:59:12
12 0,16		02:00:00
14 0,25		02:00:27
13 0,50		02:01:31
11 0,58		02:01:54
10 0,61		02:02:03
10 0,66		02:02:21
livre/ duplas pro		14

7° ENDURO 15° BPM		15
15 0,69		02:02:32
15 0,95		02:03:35
12 1,11		02:04:13
12 1,14		02:04:22
12 1,24		02:04:52
10 1,27		margeei lago 02:05:01
13 1,32		02:05:19
10 1,50 0,00		02:06:09
5 0,09		02:06:41
3 0,15		02:07:24
livre/ duplas pro		15

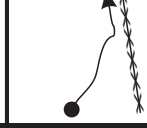
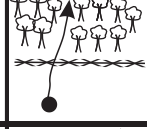
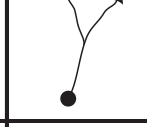
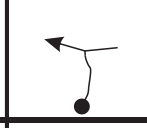
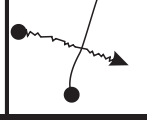
7° ENDURO 15° BPM		16
14 0,26		02:09:36
12 0,90		02:12:21
11 1,13		02:13:30
10 1,59		02:16:01
10 1,89		02:17:49
11 1,91		02:17:56
14 2,07 0,00		02:18:48
16 0,19		02:19:37
17 0,31		02:20:04
17 0,35		02:20:12
livre/ duplas pro		16

7º ENDURO 15º BPM		17
12 0,73		02:21:33
17 0,84		02:22:06
17 1,01		02:22:42
7 1,06 0,00		BAMBIS 02:22:53
18 0,13		02:23:59
15 0,21		BAMBIS 02:24:15
17 0,28		BAMBIS 02:24:32
16 0,30		02:24:36
14 0,43		02:25:06
12 0,47		pela estrada 02:25:16
livre/ duplas pro		17

7º ENDURO 15º BPM		18
12 0,78 0,04,00		mantenha fechado 02:26:49 02:30:49
6 0,94		02:31:37
10 1,27		02:34:55
12 1,52		02:36:25
12 1,76		02:37:37
12 1,96 0,00		02:38:37
12 0,35		02:40:22
12 0,45		02:40:52
5 0,69 0,04,00		NEUTRAL 02:42:04 02:46:04
8 0,78		02:47:09
livre/ duplas pro		18

7º ENDURO 15º BPM		19
8 1,10		02:49:33
8 1,23		02:50:31
8 1,39		02:51:43
8 1,49		02:52:28
5 1,53		02:52:46
<p>KbÔ</p> <p>DIA 14 DE MARÇO</p> <p>TEM MAIS</p> <p>2ª ETAPA</p> <p>ENDURO CEMIL SOY</p> <p>NO CLUBE DA ASPRA</p>		
livre/ duplas pro		20

7º ENDURO 15º BPM		20
		#DIV/0!
		#DIV/0!
		#DIV/0!
		#DIV/0!
		#DIV/0!
		#DIV/0!
		#DIV/0!
		#DIV/0!
		#DIV/0!
livre/ duplas pro		20